

A-8057/8067

Integrated Stereo Amplifier

Instruction Manual

ONKYO[®]

*****WARNING*****

TO REDUCE THE RISK OF FIRE OR ELECTRIC SHOCK, DO NOT EXPOSE THIS APPLIANCE TO RAIN OR MOISTURE.

- The serial number is written on the rear panel of this unit. Copy the serial number and model number onto your warranty card and keep it in a safe place.

Important Safeguards

1. Read Instructions — All the safety and operating instructions should be read before the appliance is operated.
2. Retain Instructions — The safety and operating instructions should be retained for future reference.
3. Heed Warnings — All warnings on the appliance and in the operating instructions should be adhered to.
4. Follow Instructions — All operating and use instructions should be followed.
5. Water and Moisture — The appliance should not be used near water — for example, near a bathtub, washbowl, kitchen sink, laundry tub, in a wet basement, or near a swimming pool, and the like.
6. Carts and Stands — The appliance should be used only with a cart or stand that is recommended by the manufacturer.
7. Wall or Ceiling Mounting — The appliance should be mounted to a wall or ceiling only as recommended by the manufacturer.
8. Ventilation — The appliance should be situated so that its location or position does not interfere with its proper ventilation. For example, the appliance should not be situated on a bed, sofa, rug, or similar surface that may block the ventilation openings; or, placed in a built-in installation, such as a bookcase or cabinet that may impede the flow of air through the ventilation openings.
9. Heat — The appliance should be situated away from heat sources such as radiators, heat registers, stoves, or other appliances (including amplifiers) that produce heat.
10. Power Sources — The appliance should be connected to a power supply only of the type described in the operating instructions or as marked on the appliance.
11. Grounding and Polarization — The precautions that should be taken so that the grounding or polarization means of an appliance is not defeated.
12. Power-Cord Protection — Power-supply cords should be routed so that they are not likely to be walked on or pinched by items placed upon or against them, paying particular attention to the cords at plugs, convenience receptacles, and the point where they exit from the appliance.
13. Cleaning — The appliance should be cleaned only as recommended by the manufacturer.
14. Nonuse Periods — The power cord of the appliance should be unplugged from the outlet when left unused for a long period of time.
15. Object and Liquid Entry — Care should be taken so that objects do not fall and liquids are not spilled into the enclosure through openings.
16. Damage Requiring Service — The appliance should be serviced by qualified service personnel when:
 - A. The power-supply cord or the plug has been damaged; or
 - B. Objects have fallen, or liquid has been spilled into the appliance; or
 - C. The appliance has been exposed to rain; or
 - D. The appliance does not appear to operate normally or exhibits a marked change in performance; or
 - E. The appliance has been dropped or the enclosure damaged.
17. Servicing — The user should not attempt to service the appliance beyond that described in the operating instructions. All other servicing should be referred to qualified service personnel.

Care

From time to time you should wipe off the front and rear panels and the cabinet with a silicon or other soft cloth. For heavier dirt, dampen a soft cloth in a weak solution of mild detergent and water, wring it out dry, and wipe off the dirt. Following this, dry immediately with a clean cloth. Do not use rough material, thinner, alcohol or other chemical solvents or cloths since these could damage the finish or remove the panel lettering.

Note:

AC Fuses

The fuses are located inside the chassis and are not user serviceable. If power does not come on, contact your Onkyo dealer.

CAUTION
TO REDUCE THE RISK OF ELECTRIC SHOCK,
DO NOT REMOVE COVER (OR BACK). NO
USER-SERVICEABLE PARTS INSIDE. REFER
SERVICING TO QUALIFIED SERVICE
PERSONNEL.

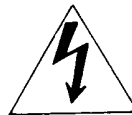

- The lightning flash with arrowhead symbol, within an equilateral triangle, is intended to alert the user to the presence of uninsulated "dangerous voltage" within the product's enclosure that may be of sufficient magnitude to constitute a risk of electric shock to persons.
- The exclamation point within an equilateral triangle is intended to alert the user to the presence of important operating and maintenance (servicing) instructions in the literature accompanying the appliance.

Front Panel Facilities

This diagram shows the A-8067 front panel. The A-8057 does not have a recording mode indicator [6] or mode selector [13].
Note: The front panel design differs slightly depending on the market for which each unit was manufactured.

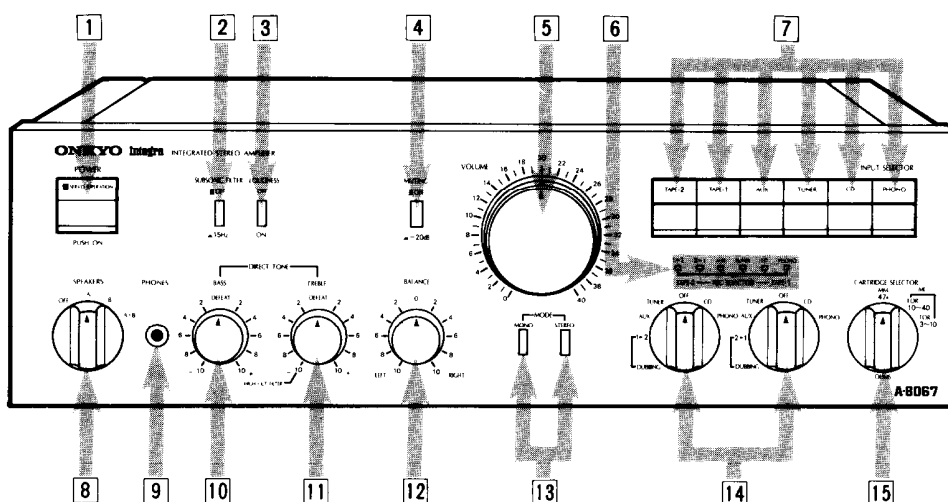

1 Power Switch (POWER)

Press once to turn power on and once again to turn power off. When power is turned on, the orange band over the power switch lights. After a few seconds, the Servo Operation indicator lights green to show that the Super Servo circuitry has stabilized. No sound is heard until this indicator lights green.

2 Subsonic Filter (SUBSONIC FILTER)

The subsonic filter cuts off all frequencies below 15Hz, thus eliminating motor rumble and other inaudible subsonic frequency noises responsible for distortion in the bass region.

3 Loudness Control (LOUDNESS)

When listening at very low volume levels, depress this button to boost the very high and very low frequency ranges to produce a more natural sound.

4 Muting Switch (MUTING)

When this switch is set to the -20dB position, the volume level is reduced to one-tenth of the level set by the volume control.

5 Volume Control (VOLUME)

Turn clockwise to increase the volume level.

6 Recording Mode Indicator (only A-8067)

Shows the current settings of the recording source selectors [14]. If the TAPE-1 selector is set to 2 ► 1 and the TAPE-2 selector is set to 1 ► 2, only the 1 ► 2 indicator will light; the 2 ► 1 indicator will remain off.

7 Input Selector Switches (INPUT SELECTOR)

These switches are used to select the desired program source. The buttons are interconnected; depressing one causes the previously depressed button to come up. An indicator lights to clearly show which program has been selected.

TAPE-2: Depress to listen to the tape deck connected to the TAPE-2 terminals.

TAPE-1: Depress to listen to the tape deck connected to the TAPE-1 terminals.

AUX: Depress to listen to the component connected to the rear panel AUX terminals.

TUNER: Depress to listen to the tuner connected to the TUNER terminals.

CD: Depress to listen to the compact disc player connected to the CD terminals.

PHONO: Depress to listen to the turntable connected to the PHONO terminals.

8 Speaker Selector (SPEAKERS)

This unit can drive two pairs of speaker systems at once. Use this selector to switch between the speaker systems connected to the rear panel speaker terminals. In the OFF position, sound

is heard only through the headphones.

OFF: All speakers off — only headphones operating

A: Speakers A operating

B: Speakers B operating

A+B: Both speaker systems A and B operating

9 Headphones Jack (PHONES)

Stereo headphones with a standard binaural plug can be connected here.

10 Bass Control (BASS)

Adjust to boost or attenuate bass. In the center position (DEFEAT), the bass tone control circuitry is completely bypassed.

11 Treble Control (TREBLE)

Adjust to boost or attenuate treble. In the center position (DEFEAT), the treble tone control circuitry is completely bypassed. When turned all the way to the left (-10), the treble control acts as a high cut filter to eliminate scratches, hissing and other high frequency noise.

12 Balance Control (BALANCE)

This is used to control the relative volume level of the left and right speaker systems or headphones.

13 Mode Selector (MODE) (only A-8067)

STEREO: This is the normal use position for stereo listening.

MONO: Both right and left channel signals are sent to each speaker. Use this position for listening to monaural recordings or when adjusting the balance.

14 Recording Source Selectors (REC. SELECTOR)

This unit is equipped with separate recording source selectors for tape decks 1 and 2 so that the two decks can be used to record different program sources at the same time.

2 ► 1: Use either of these settings for tape dubbing operations depending on which deck is being used for playback and which is being used for recording. For details, refer to the Operations section.

1 ► 2: Use either of these settings for tape dubbing operations depending on which deck is being used for playback and which is being used for recording. For details, refer to the Operations section.

AUX: When recording from the component connected to the rear panel AUX terminals.

TUNER: When recording from the tuner

OFF: When not recording or dubbing

CD: When recording from the CD player

PHONO: When recording from the turntable

- 15 Cartridge Selector (CARTRIDGE SELECTOR)**
MM: When a turntable with an MM cartridge is being used.
MC: When a turntable with an MC cartridge is being used.

Use the MM position when a step-up transformer is being used with a turntable equipped with an MC cartridge. This cartridge selector has two positions for MC cartridges, one for the 10-40 ohm and another for the 3-10 ohm impedance range. Set to the correct position for the output impedance of the MC cartridge being used.

System Connections and Rear Panel Facilities

Do not plug in the power cord until all connections have been made.

- 16 AC Outlets (UNSWITCHED)**
 These outlets are not switched on and off by the power switch on the front panel. Capacity is 100 watts for each outlet (total of 200 watts).
- 17 AC Outlet (SWITCHED)**
 This outlet is switched on and off by the power switch on the front panel. Capacity is 100 watts.

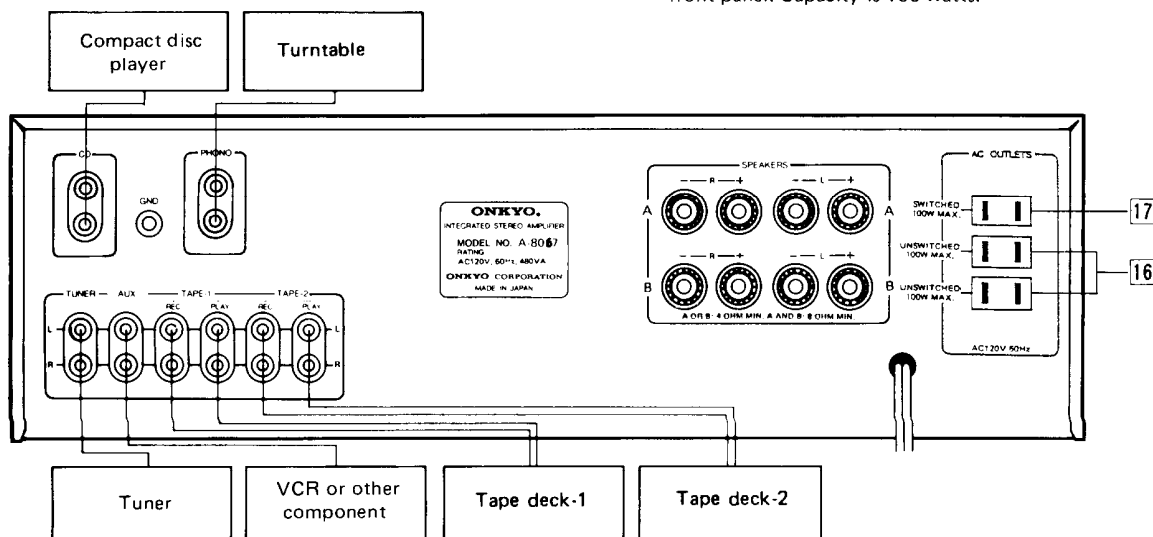

General

On each pair of input or output jacks, the lower jack (marked R) corresponds to the right channel, and the upper jack (marked L) to the left channel. When jacks on other equipment or connection cables are color-coded, the color red usually corresponds to the right channel (Red = Right).

Turntable Connections

Be sure to connect the ground (earth) lead wire from the turntable to the ground terminal (GND). Lack of proper ground connection will cause hum. Also observe the following precautions.

- Place the turntable on a firm shelf or desk free from vibrations (especially those generated by the speaker systems). If the turntable is permitted to pick up such vibrations, not only will this unit's performance suffer, but distortion in the bass range and howling noise in the speakers may also occur.
- Check the turntable instruction manual for any other precautions.
- The loud noises that occur when connecting and disconnecting the turntable leads could damage the speakers. Always turn the power switch off before making connections.

Speaker Connections

When connecting speakers, proper polarity is important. Always connect the (+) terminal (red) on the amplifier to the (+) terminal on the speaker and the (-) terminal (black) on the amplifier to the (-) terminal on the speaker. Two separate pairs of speaker systems can be connected to this unit at once.

- The load impedance of each speaker system connected to this unit must be at least 4 ohms. (A or B — 4 ohm min., A and B — 8 ohm min.)
- When using only one speaker or when you wish to listen to monaural, the single speaker should never be connected in parallel to both the right and left channel terminals at once.
- Do not use unnecessarily long or extremely thin speaker leads. If the DC resistance of the speaker leads is too high, the damping factor will decrease.

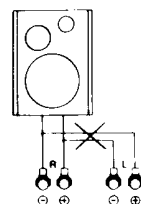

Connecting Speaker Leads to the Speaker Terminals

1. Strip off the insulation about 15mm back from the end of the wire.
2. When using stranded wire, twist it so that the separate wires will not come unraveled.
3. Loosen the speaker terminal fasteners, wind the speaker wires around the bases of the screws, and tighten down the fasteners securely.
4. Be sure to avoid short circuits in the speaker connections.

Tape Deck Connections

Two tape decks can be connected at once to this unit. Connect the tape deck output leads to the PLAY jacks and the tape deck input leads to the REC jacks of this unit. For more details, refer to your tape deck owner's manual.

Compact Disc Player Connections

Connect a compact disc player to the CD input terminals. Be sure the left and right channels are connected properly. A second compact disc player may also be connected to the AUX input terminals.

Tuner Connections

Connect an FM/AM tuner to the tuner input terminals. Be sure the left and right channels are connected properly. A second tuner may also be connected to the AUX input terminals.

Auxiliary Connections

This unit's AUX input terminals are designed for connection to a wide range of audio components such as an additional compact disc player, an additional tuner, a television set, a VCR, a 4-channel stereo adaptor and other similar components.

Operations

Connect all components to the rear panel terminals as shown in the connections section and set the front panel controls in the appropriate settings to hear the desired program source.

Normal Standby Mode

The standby positions of front panel controls and switches serve as the starting point for all operating modes.

2	Subsonic Filter	OFF
3	Loudness Control	OFF
4	Muting Switch	OFF
5	Volume Control	minimum (all the way to the left)
7	Input Selector	as desired
8	Speaker Selector	as desired
10	Bass Control	Center
11	Treble Control	Center
12	Balance Control	Center
13	Mode Selector	STEREO
14	Recording Source Selectors	OFF
15	Cartridge Selector	as desired
1	Power Switch	ON

Using Tape Decks

Playback:

Two tape decks can be connected to this unit at once. If the deck connected to the TAPE-1 terminals is to be heard, depress the TAPE-1 selector switch [7]. To listen to the deck connected to the TAPE-2 terminals, depress the TAPE-2 selector switch [7].

Recording:

Set the recording source selector [14] to the PHONO, CD, TUNER or AUX position depending on which one is to be used as the program source and begin recording operations. If you are recording on a 3-head tape deck, depress the input selector switch [7] corresponding to the tape deck in use to monitor the just-recorded signal. If the input selector [7] is in any other position, another audio source can be heard while recording is in progress.

Set the proper recording level using the controls on the tape deck. Also, during recording and dubbing operations, never change the positions of any switches on this unit, particularly the mode selector [13].

Tape-to-Tape Duplicating

When two tape decks are connected at once to this unit, a tape can be copied from one deck to the other. To copy a pre-recorded tape from tape deck 1 (the deck connected to the rear panel TAPE-1 terminals) to tape deck 2 (connected to the TAPE-2 terminals), perform the following procedure.

1. Place the TAPE-2 recording source selector [14] in the 1 ► 2 position and put tape deck 1 in the playback mode and tape

deck 2 in the recording mode. If tape deck 2 is a 3-head deck, the just-recorded signal can be monitored by depressing the TAPE-2 selector switch [7]. To monitor the signal from tape deck 1 before it has been recorded, depress the TAPE-1 selector switch [7]. Depress one of the other input selector switches to listen to the CD player, turntable, tuner, or auxiliary component while dubbing is taking place.

2. To copy from tape deck 2 to tape deck 1:
Place the TAPE-1 recording source selector [14] in the 2 ► 1 position and put tape deck 1 in the recording mode and tape deck 2 in the playback mode. If tape deck 1 is a 3-head deck, the just-recorded signal can be monitored by depressing the TAPE-1 selector switch [7].

Note: When the TAPE-1 recording source selector is set to 2 ► 1 and the TAPE-2 recording source selector is set to 1 ► 2, dubbing is possible only from tape deck 1 to tape deck 2.

About the Variable Bass and Treble Boosting System

This unit is designed to gradually reduce the effect of the tone controls (bass and treble) as the volume exceeds a certain level. The variable boosting system gradually reduces the boosting effect of the bass [10] and treble [11] controls when one or both of these controls is turned beyond (to the right) the center defeat position and the volume control [5] is turned beyond the 20 graduation (the 12:00 position). When the volume is turned all the way up, the frequency response will be flat again. Volume settings below the 20 graduation have no effect on the tone controls. Also, bass and treble control settings below (to the left) the center defeat position are not altered by the volume level.

Using a Mixing Console or Graphic Equalizer

A mixing console or graphic equalizer can be connected to the TAPE-1 (or TAPE-2) terminals as shown in the diagram. The input selector is then set to the TAPE 1 (or 2) setting, depending on the terminals to which the mixing console or equalizer is connected and the recording source selector to the program source to be used with mixing or equalization. To perform mixing or equalization with a tape deck program, set the recording source selector to 2 ▶ 1 (or 1 ▶ 2) for mixing or equalizing the tape program from tape deck 2 (or tape deck 1).

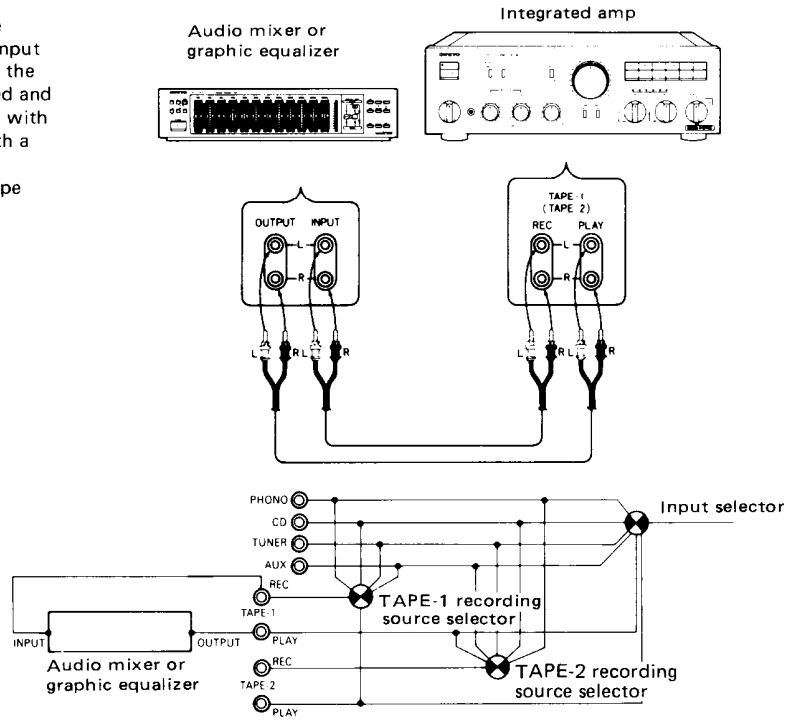

Trouble-shooting Guide

Problem	Cause	Remedy
No power.	<ul style="list-style-type: none"> ● AC fuse blown. 	<ul style="list-style-type: none"> ● Contact Onkyo dealer.
Power but no sound.	<ul style="list-style-type: none"> ● Bad connections. 	<ul style="list-style-type: none"> ● Check input leads, speaker leads, pin plugs, etc.
Hum, low frequency noise.	<ul style="list-style-type: none"> ● Poor or no input ground. ● Poor or no phono motor ground. ● Power source hum. 	<ul style="list-style-type: none"> ● Check outer conductor of input plugs. ● Check for proper ground connection. ● Try reversing AC plug in socket.
Howling when the volume is turned up.	<ul style="list-style-type: none"> ● Turntable and speakers are too close together. 	<ul style="list-style-type: none"> ● Move them farther apart.
Rough or scratchy sound. High range is not clear.	<ul style="list-style-type: none"> ● Stylus of pick-up is worn. ● Stylus is dirty. ● Treble control is too high. 	<ul style="list-style-type: none"> ● Replace. ● Clean. ● Turn treble control down.

Specifications

A-8057

Power Output: 65 watts per channel, min. RMS, at 8 ohms, both channels driven, from 20Hz to 20kHz, with no more than 0.018% THD.

Total Harmonic Distortion: 0.018% at rated power

IM Distortion: 0.005% at rated power

Damping Factor: 50 at 8 ohms

Frequency Response: 2 – 50,000 Hz \pm 1dB

RIAA Deviation(MM): 20 – 20,000 Hz \pm 0.5dB

Sensitivity and Impedance: Phono(MM): 2.5mV/50 kohms
Phono(MC): 160 μ V/100/220 ohms
Tuner: 150mV/50 kohms
Tape Play: 150mV/50 kohms
Tape Rec: 150mV/1.5 kohms (phono)

Phono Overload: 200mV RMS at 1kHz, 0.018% THD

Bass Control: \pm 8 dB at 70Hz

Treble Control: \pm 8 dB at 20,000Hz

Signal to Noise Ratio: Phono(MM): 80dB (IHF A-202, 5mV input, 1 watt output)
Phono(MC): 70dB (IHF A-202, 0.5mV input, 1 watt output)
Tuner & Tape: 84dB (IHF A-202, 0.5V input, 1 watt output)

Muting: –20 dB

Loudness Control: +6 dB at 70Hz, +5 dB at 20kHz

Subsonic Filter: 15Hz (6dB/Octave)

High Cut (TREBLE MIN): 6kHz (6dB/Octave)

A-8067

Power Output: 80 watts per channel, min. RMS, at 8 ohms, both channels driven, from 20Hz to 20kHz with no more than 0.015% THD.

Total Harmonic Distortion: 0.015% at rated power

IM Distortion: 0.005% at rated power

Damping Factor: 50 at 8 ohms

Frequency Response: 2 – 50,000 Hz \pm 1dB

RIAA Deviation(MM): 20 – 20,000 Hz \pm 0.3dB

Sensitivity and Impedance: Phono(MM): 2.5mV/50 kohms
Phono(MC): 160 μ V/100/220 ohms
Tuner: 150mV/50 kohms
Tape Play: 150mV/50 kohms
Tape Rec: 150mV/1.5 kohms (phono)

Phono Overload: 200mV RMS at 1kHz, 0.015% THD

Bass Control: \pm 8 dB at 70Hz

Treble Control: \pm 8 dB at 20,000Hz

Signal to Noise Ratio: Phono(MM): 80dB (IHF A-202, 5mV input, 1 watt output)
Phono(MC): 72dB (IHF A-202, 0.5mV input, 1 watt output)
Tuner & Tape: 84dB (IHF A-202, 0.5V input, 1 watt output)

Muting: –20 dB

Loudness Control: +6 dB at 70Hz, +5 dB at 20kHz

Subsonic Filter: 15Hz (6dB/Octave)

High Cut (TREBLE MIN): 6kHz (6dB/Octave)

General

Power Supply: AC120V, 60Hz

Semiconductors: IC: 4 TR: 38 Diode: 43

Dimensions: 435(W) x 144(H) x 391(D)mm
17-1/8" x 5-5/8" x 15-3/8"

Weight: 10.5 kg. (23.2 lbs.)

Power Supply: AC120V, 60Hz

Semiconductors: IC: 5 TR: 42 Diode: 46

Dimensions: 435(W) x 144(H) x 391(D)mm
17-1/8" x 5-5/8" x 15-3/8"

Weight: 12 kg. (26.5 lbs.)

Specifications and features are subject to change without notice.